

# DIY Cloth Face Mask

## General Notes



Because of the Covid-19 virus everyone has been asked to wear a face mask in public. YouTube and the Internet has become flooded with DIY instruction for making one's own cloth face mask. There are a lot of great videos out there and I have watched a bunch of them. However no matter how hard I tried I could not get the pleats right. That and the thing kept sliding off my big nose. Who knew a simple cloth face mask could be so complicated???? So I decided to enter the fray by drawing my own patterns.

This is NOT intended to be a N95 medical mask. The goal here is to produce a reusable, washable mask for 'the rest of us' to wear in public to reduce that chance of either spreading or catching the disease. I will leave the more complex and critical masks to the industrial experts and/or very skilled home crafters.

This document/file is placed in the **PUBLIC DOMAIN**.

Disclaimer: The author assumes no liability for the accuracy, fitness or application of the information or design(s) herein.

Lewis Balentine, Houston, Texas, 15 May 2020

## Fabrics:

What to use? It seems the most popular fabric is common 100% cotton plain woven quilting fabric or similar fabric salvaged from old shirts, dresses, sheets or pillow cases. These tend to be 'breathable' and offer protection from droplets. These fabrics may also be listed by a weight of 4 to 5 ounces per square yard.

Stretch knit fabrics like cotton T-shirts make the most comfortable masks but the stretchable fabric may be harder for in-experienced sewers to work with. Walking around with two layers of heavy T-shirt knit material on your face in hot weather is NOT likely to be very comfortable. I have also tried a very sheer silk fabric but it was also extremely difficult to work with.

In theory one should use a different pattern/color for the inside and outside of the face mask so that it is obvious which side is to be placed against the one's face.

## Thread:

Use what you got. Any 50 weight cotton, polyester, cotton-polyester or all purpose twisted sewing thread and a standard 80/12 needle should be fine. Silk is also suitable but those threads tend to be much finer (*thin diameter*) and thus may require smaller needles or other considerations (*having said that I use 50 wt silk for its added strength*). **WARNING:** Maximum ironing temperature for silk or 'all purpose polyester' thread is about 300 degrees Fahrenheit. **Reference:** <https://en.wikipedia.org/wiki/Ironing>

## Straps:

First of all, unless the mask is being made for a specific individual the strap should be adjustable. The easiest thing to do is to make a mask that ties in back. However those can be inconvenient if one wants something that can be quickly removed and replaced. A lot of people prefer straps that they can hook over their ears. While some people have what might be considered 'normal' ears, there are those of us that have such huge ears that they would make Jumbo blush with envy.

One can try to circumvent this problem by using some form of elastic but alas recent demand exceeded supply resulting in said material becoming hard to come by. That problem has been somewhat reduced in recent weeks. Elastic that uses silicon rubber is best. It can withstand both high heat and caustic chemicals like chlorine bleach and hot irons. I made some straps by cutting 7.5mm wide strips from a silicon cooking mat. The best alternative that I have found is 'no-tie' shoe laces (*the highest quality ones use braided cotton and silicon rubber*). Each lace is about 40 inches (*1 meter*) long by about 1/4 inch wide and very stretchy.

Another alternative is to use cotton shoe laces with a slip knot. One such knot I found that will work is the Magnus knot (*see the last page of this document*). In some case a simple overhand knot will work as well. Then you can have all natural, organic materials in your mask. Speaking of shoe laces: This idea was inspired by James Bond 007 "For Your Ears Only". As an alternative one can use common 5/32 inch diameter parachute chord (*a.k.a. Mil Spec 550 Type III paracord*). I suggest stripping out the internal fiber core of

paracord (*that makes it flatten out much like shoe laces*). Be warned a hot iron should not be used on any synthetic fiber but most especially nylon (*max ironing temperature between 150-170 degrees Fahrenheit*).

Another alternative, the one I prefer, is to use a set of craft beads such that the straps can be pulled through the beads to adjust the length on the straps. A 6 x 9 mm plastic bead with a 4mm hole (*aka PONY Beads*) works well with shoe laces. I am now equipping all my mask with elastic straps and beads. The straps are cut long and the user can remove any excess with a pair of scissors.



## Nose Piece:

Does one really need a nose piece. If one wears glasses that is a very big affirmative. Otherwise one's hot, moist exhaled breath tends to fog the lenses. Others may want a nose-piece in order form a better, more comfortable fit around the nose. I found that 3 inches (*75 millimeters*) was the best length to bridge my rather large protrusion. One can order aluminum nose-pieces via Ebay or Amazon that are between 3 and 4 inches long (*75 to 100 millimeters*) but delivery time may be as long as two months (*note: that problem has largely disappeared*). Other alternatives are pipe cleaners, '2 Inch capacity prong report binder' bases, heavy duty twist ties, millinery wire, small gauge copper wire or paper clips.

I found that the 'report binders' worked excellent if I cut them down to about 3 inches in length and then used a hammer to flatten the centers a bit. The nose-piece can be wrapped with tape or cloth to adjust the stiffness and/or act as a cushion.



*Report Binder: clipped, bent and flattened*

<https://www.amazon.com/dp/B000093KXE>

## **Avoid the Pucker, use Button holes:**

I have made a couple dozen masks with no two alike. My goal was to come up with something that was washable, reusable with replaceable nose-piece and straps. The original design I posted had various sizes as well as pockets for the nose piece and the straps along with variations for both narrow and wide pleats. I have since learned that the strap pockets almost always cause the mask to 'pucker' on the ends. I now use button holes on all my masks. I have found that 3/8 inch long button holes work well for both the straps and the nose piece and thus I do not need to re-adjust my "button hole" presser foot.

## **Location, Location Location:**

It turns out that the location of the straps makes a great deal of difference in how well the mask conforms to the face. Another variable is in how one actually wears the mask. Most people will loop them over the ears with the top strap over the top of the ear. However some people wear them with the bottom strap over the top of the ear and the top strap underneath the ear (*aka 'cross strap'*). The latter is particularly the case when a rectangular mask is worn with the lower portion under the chin against the neck.

For the folks that wear the mask with the top strap over the top of the ear the 'eyes' have it. The top of the eye and top of the ear are at approximately the same height. Thus the top strap location should be at the very top of the mask. I found the lower location works well if it is about level or slightly below the level of the mouth. The feed dogs on my Singer sewing machine are spaced such that 10mm ( $\frac{3}{8}$  inch) is the closest I can get to the side edge of the cloth and reliably feed the material using the button hole presser foot.

The same locations seem work passably well for the 'cross strap' wearers as well. One thing to note is that when worn in this fashion with the bottom under the chin then the side edges of most mask tend to pucker unless they have an appropriate "dart" incorporated in those sides.

## **Pleats:**

OH those pleats! That is what started me on this quest to begin with. How to get nice even straight pleats? My first success came from using a single hand stitch to bring the pleats together and 'tack' them in place until they are firmly sewn into place with the sewing machine. Alas many times I wound up having to tie the 'thread tails' to keep the stitch in place. For that I had to use two pairs of tweezers and a magnifying glass. Fortunately I now have some 'Wonder Clips' that I use to hold the pleats in place ... no, straight pins are NOT a viable alternative.



Another trick I use is to place a "pin tuck" along the bottom edge of the outside fold of each of the pleats. It should be just wide enough to catch both layers of the material. Most of my masks are made of 100% cotton cloth. The pin tuck helps maintain the definition of the pleat through the laundry cycle and simplifies ironing the mask. In most case one does NOT want a pin tuck on the inside folded edge. This edge needs to be able to "roll" as the mask adjust to the users face or the user is speaking. In some case I place a short pin tuck along the inside folded edge near the sides of the mask but I always leave the center portion free to roll.

## Fabric Marking:

I recommend **Pilot FriXion** markers or pens to mark the cutting and stitch lines on the fabric. The ink from these pens will disappear with application of heat (*steam iron or laundry drier*). I believe that the ink washes out in the normal laundry cycle but have no way to verify that. Do not forget to lock stitch and/or tie the 'thread tails' at the ends of the seams.

I have NOT found a good solution for marking dark fabrics. I have tried using 'soap stone' markers but they 'set' into the fabric when ironing the masks between various construction stages. The best solution that I have found is to avoid dark fabrics.

## Mask Sizes:

Most of the patterns on my web site are sized for adults. The pleats and replaceable straps should allow them to fit most adults. If some adjustment is needed then the patterns are in vector based PDF format and most operating systems can print them at a reduced or enlarged scale.

Sizing a mask for a child is a bit more of a challenge ... particularly as I am a single male with no children. The most viable alternative is to measure the circumference of the child's head (*as in 'HAT SIZE'*) and then scale the pattern proportionally from the adult size. For reference my head measures 22-1/2 inches (57 cm) in circumference.

I have also searched the internet to find some information. I offer the following for whatever use it may be (*or not*):

<https://www.dkfindout.com/us/human-body/life-cycle/changing-proportions/>

At birth a newborn baby's head makes up more than one-quarter of the baby's total length.

By the age of two, the head makes up a quarter of the total body height.

By the age of six, the head is much more in proportion.

By the age of ten, the head is just over one-eighth of the total body height.

At final adult height, the head is only about one-eighth of the total body height.

So I '*borrowed*' the chart from the that resource and scaled the head heights:

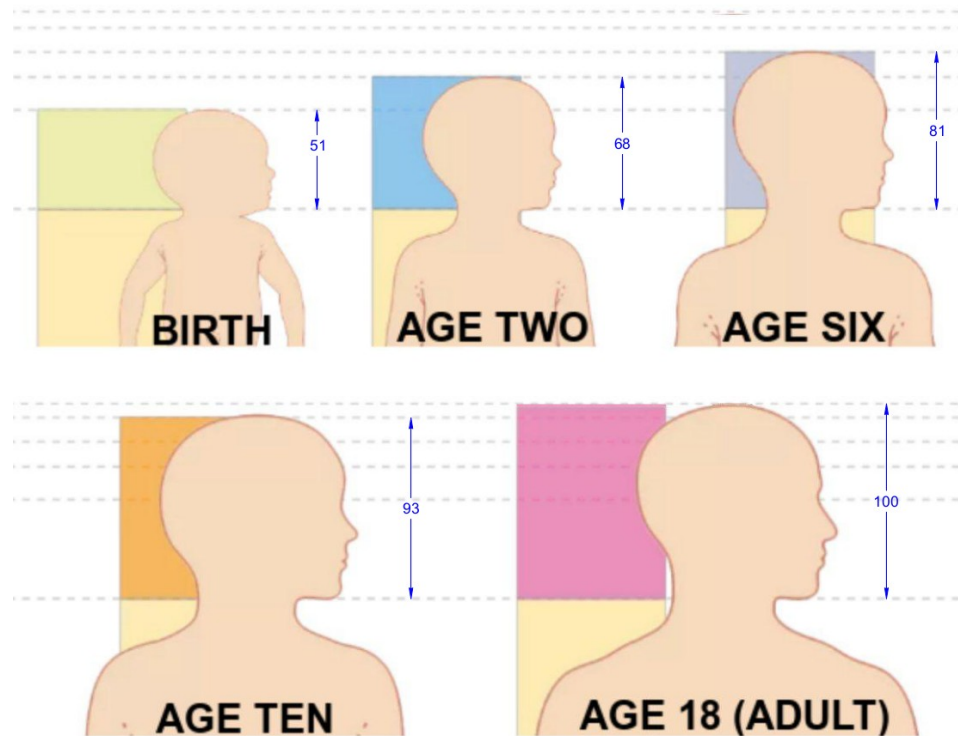

Now if one assumes (*always a risky proposition*) that their information and chart are correct then one can extrapolate from these five data points:

<b>Age</b>	<b>Data Point</b>	<b>Extrapolated</b>	<b>Rounded</b>
Birth	51	51	51%
1		59.5	60%
2	68	68	68%
3		71.25	71%
4		74.5	75%
5		77.75	78%
6	81	81	81%
7		84	84%
8		87	87%
9		90	90%
10	93	93	93%
12		94.75	95%
14		96.5	97%
16		98.25	98%
18	100	100	100%



## Last Minute Notes (Updated May 2020):

Brittany Bailey's "**Pretty Handy Girl**" website has a simple "Cup Style" mask design:

<https://www.prettyhandygirl.com/best-fit-face-mask/>

"**Smart Air**" has a good reference "*What Are The Best Materials for Making DIY Masks?*" that can be accessed at the following URL:

<https://smartairfilters.com/en/blog/best-materials-make-diy-face-mask-virus/#>

The original **PDF** file for this document can be found at my website on the page:

<http://www.keywild.com/facemask>

The CAD files (patterns) were produced with the cad software "**BricsCAD Pro**" Version 18.2. This is one of the few professional CAD systems available that runs under Linux.

[https://www.bricsys.com/?site=en\\_US](https://www.bricsys.com/?site=en_US)

Separate PDF pattern sheets were combined into a single PDF document using the software "**Master PDF Editor**" build 5.3.22

<https://code-industry.net/>

Some people need vector based SVG files to use with pattern cutting machines. These can be produced from the vector based PDF files using the **InkScape** SVG software:

<https://inkscape.org/>

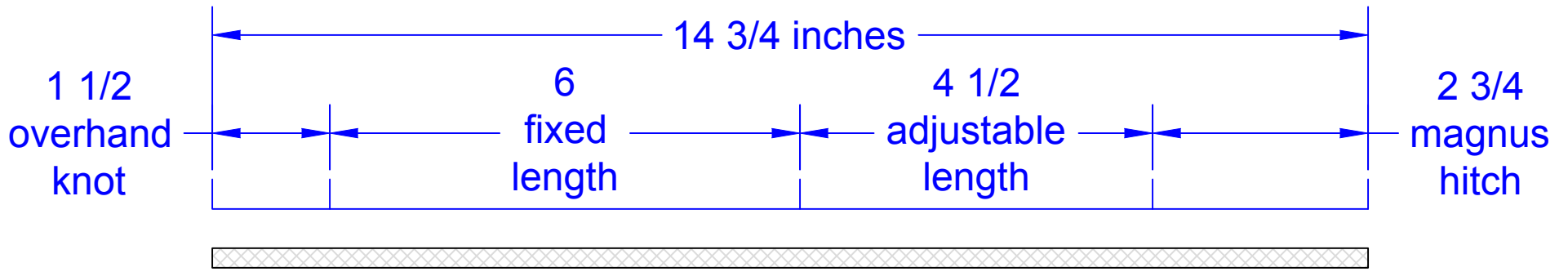

Cotton Shoe Lace  
or

Type III Paracord (Mil Spec 550), 5/32 inch (4.0mm) diameter  
Polyester or Nylon Braided Sheath Only (*stripped of internal core fibers*)

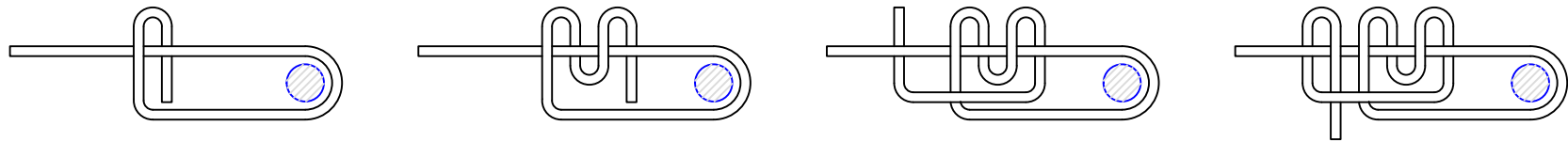

These are the steps to tie the Magnus hitch variation of a taut-line hitch.  
You can also reference the URL [https://en.wikipedia.org/wiki/Taut-line\\_hitch](https://en.wikipedia.org/wiki/Taut-line_hitch)  
or it is the 3rd knot in the Youtube video <https://youtu.be/lm1GEbcObz0>

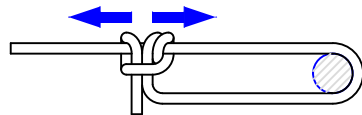

When the line is loose, the knot can be slid along the line to adjust the length

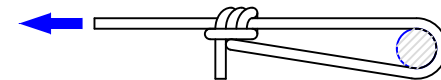

When the line is taunt, the knot will not slide